



TEST OUR METAL™

Job: _____

Item No. _____

Mobile Cabinet

Ambient Transport and Storage Cabinet For 18X26 or 14X18 Trays

- Aluminum Construction with reinforcement channels welded between corner posts for added support and rigidity.
- Heavy-Duty Frame and interlocking side panels of 6063-T5 architectural aluminum for air tight seal and structural rigidity. Bottom and welded hat channels for casters are welded .100" aluminum.
- Doors open 270 degrees, are equipped with center reinforcement and heavy duty flag hinges. Comes standard with built in Flush Mounted Door Handle.
- Designed to hold 18" X 26" or 14" X 18" trays with 1 1/2" spacing.
- 5" plate type swivel casters, 2 with brakes.
- Optional Lexan Door Available.

Models

- EC-1442-R
- EC-1474-R



EC-1474-R shown optional perimeter bumper



Made in USA

451 E. County Line Rd. • P.O. Box 236 • Mooresville, IN 46158
 Toll Free 800-733-8073 • Local 317-831-7030 • Fax 317-831-7036
www.secoselect.com

MODEL #	TRAYS CAPACITY		PANS CAPACITY		HEIGHT DIM A	WIDTH DIM B	DEPTH DIM C	SHIPPING CUBE FEET	SHIP WEIGHT
	18x26	14x18	20X24	12X20					
EC-1442-R	21	42	N/A	N/A	42 1/2"	23"	35"	19	100
EC-1474-R	37	74	N/A	N/A	65 3/8"	23"	35"	30	120

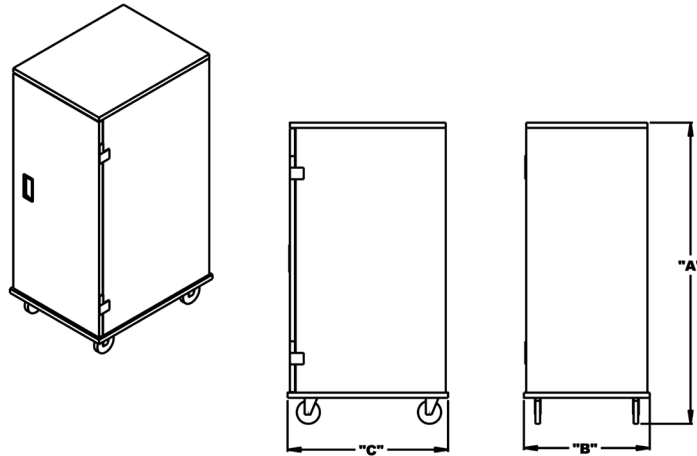

GENERAL: Cabinet shall be all aluminum construction. Cabinet shall have aluminum frame and .90" thick interlocking side panels that are riveted into position.

INTERNAL FRAME: Cabinet shall be framed with 1 1/2" x 1 1/2" x 1/8" thick 6063-T5 aluminum tubing in the front and back. Frame shall be fully welded.

BASE: Base shall be .125 Aluminum and shall be reinforced with 1/8" thick aluminum cross braces.

INNER CABINET: Inner cabinet shall be all aluminum construction. Cabinet shall accommodate 18" x 26" sheet pans. *

DOOR: Door shall be constructed of .063 aluminum and shall be reinforced. Door shall have two (2) heavy-duty, 5/8" thick extruded flag type hinges. Door shall be removable without tools and shall have recessed handles. Door shall have a heavy-duty positive action magnetic latch.

CASTERS: Cabinet shall come complete with 4-5" non-marking plate casters, 2 rigid and 2 swivel. Casters shall have a weight capacity of 200 lbs each.

*Model EC – 1237 – R accommodates 12 x 20 steam pans only.

Accessories, Options, Variations

- Push Handle With Donut Bumpers
- Transport Locks
- Dutch Style Doors
- Door Gaskets
- RSG – Right Hand Lexan Door (On Select Models)
- LSG – Left Hand Lexan Door (On Select Models)
- Left Hand Door (no additional charge)

We reserve the right to change specifications and product design without notice. Such revisions do not entitle the buyer to corresponding changes, improvements, additions or replacement for previously purchased equipment.



TEST OUR METAL™

451 E. County Line Rd. • P.O. Box 236 • Mooresville, IN 46158
800-733-8073 • Local 317-831-7030 • Fax 317-831-7036
www.secoselect.com

REV 2013-1